

6 5 4 3 2 1

D

D

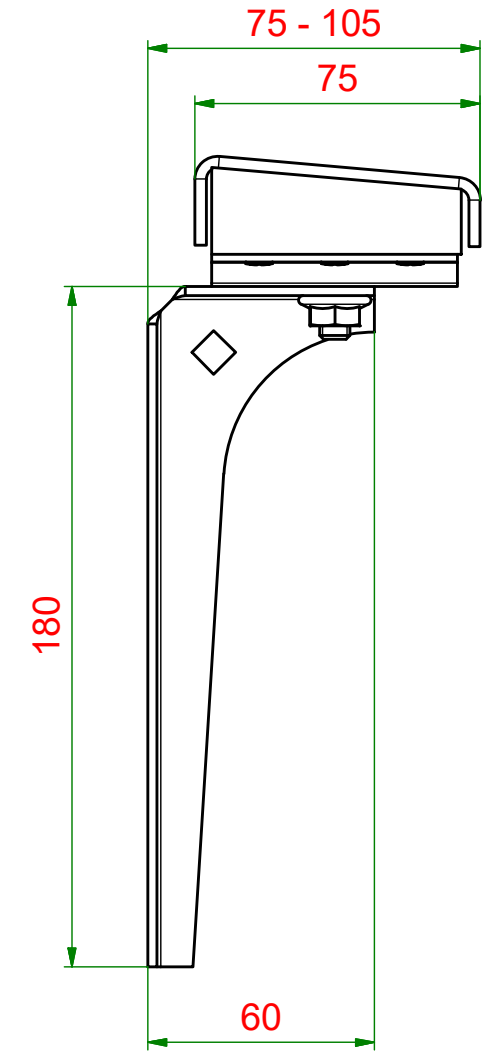
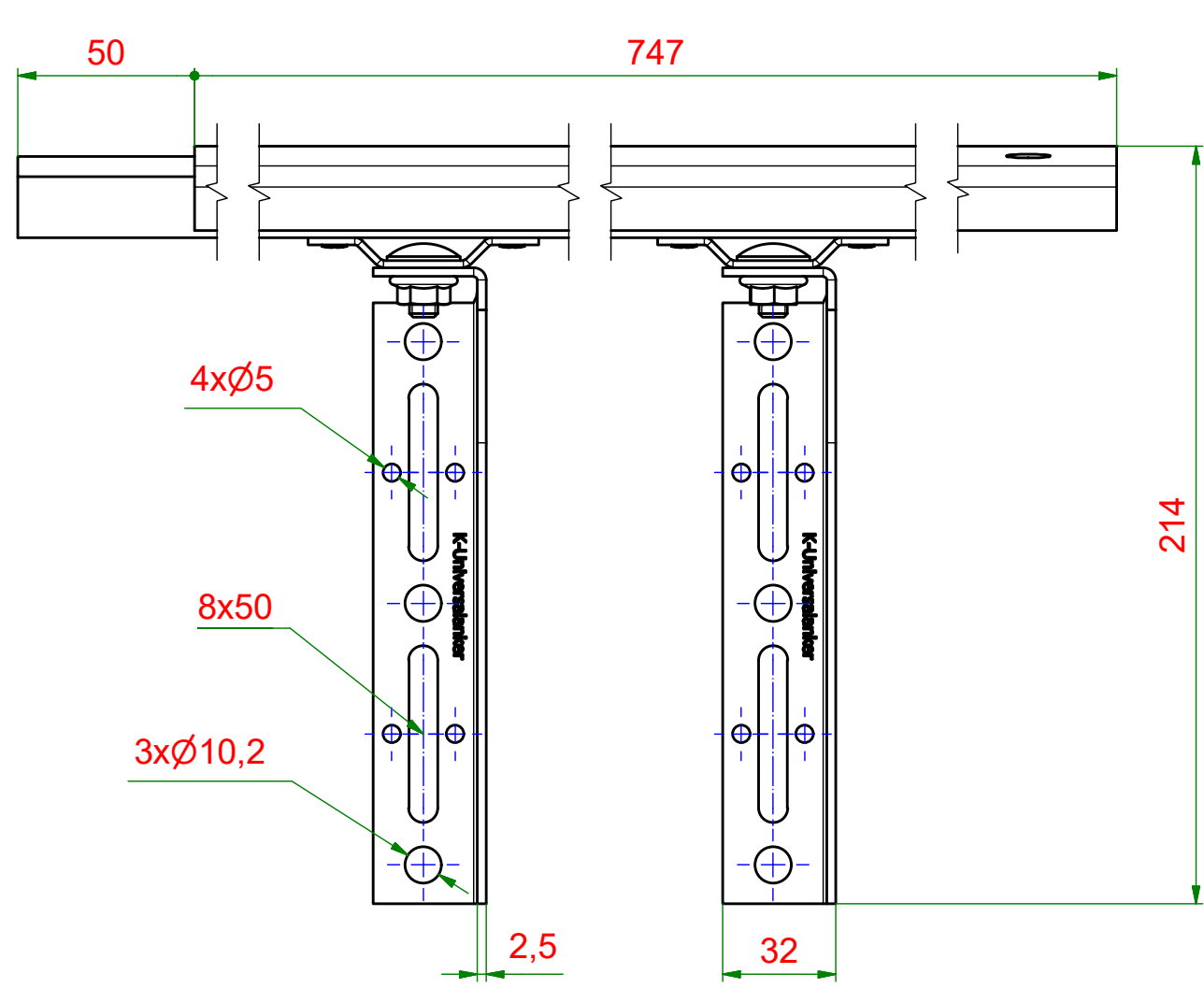

C

C

B

B

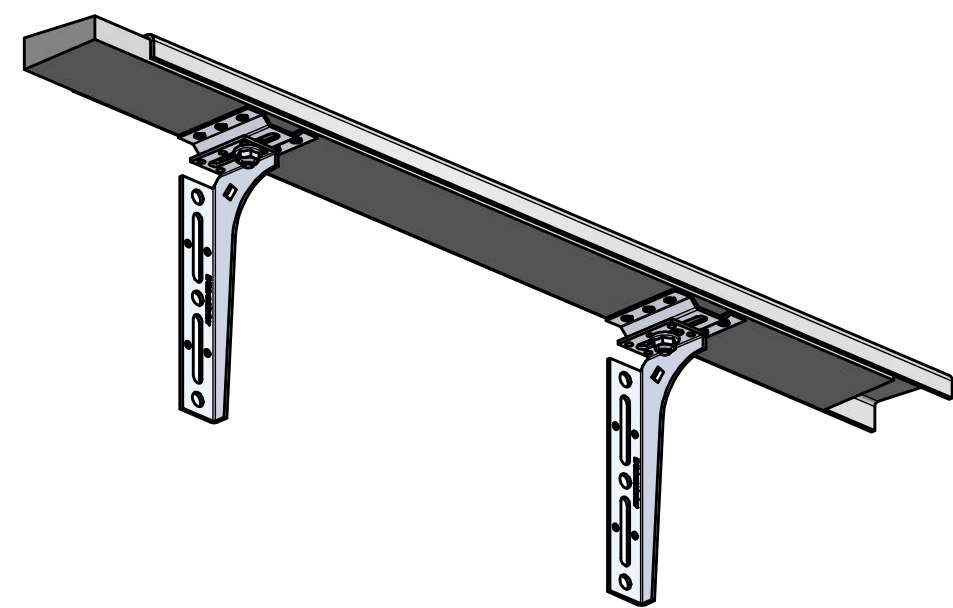

A

A

6 5 4 3 2 1

<p>KNELSEN Entwicklung und Herstellung</p>			Material: verzinkter Stahl									
	<table border="1"> <tr> <td>Datum</td> <td>Name</td> </tr> <tr> <td>Erstellt 20.01.2023</td> <td>R.Heiermeier</td> </tr> <tr> <td>Genehmigt</td> <td></td> </tr> </table>		Datum	Name	Erstellt 20.01.2023	R.Heiermeier	Genehmigt		<table border="1"> <tr> <td>Maßstab: 1 : 2</td> <td>Masse: 1.82 kg</td> </tr> </table>		Maßstab: 1 : 2	Masse: 1.82 kg
	Datum	Name										
	Erstellt 20.01.2023	R.Heiermeier										
Genehmigt												
Maßstab: 1 : 2	Masse: 1.82 kg											
<p>Knelsen GmbH Am Schlinge 26 33154 Salzkotten Tel.: 05258 / 93766-95 Fax: 05258 / 93766-97 www.knelsen.de info@knelsen.de</p>		<p>Titel, Beschreibung</p> <p>T-SFBH-begehrbar 130-165 Thermo-Steifensterbankhalter begehrbar</p>										
<p>Allgemeintoleranzen nach ISO 2768-m</p> <p>Schutzvermerk nach DIN ISO 16016 beachten</p>		<p>Bauteilnummer / Zeichnungsnummer</p> <p>405320</p> <p>Revision: 2</p>										

Blatt 1

A3